

# Aussie™ Charcoal Grill

## Assembly and Use Manual



MONARO™ 7652

© Aussie Grill Company 2000

FOR CUSTOMER SERVICE CALL 1-800-251-7558



- READ AND FOLLOW INSTRUCTIONS CAREFULLY BEFORE ASSEMBLY OR USE. FAILURE TO FOLLOW THESE INSTRUCTIONS COULD RESULT IN DEATH, SERIOUS BODILY INJURY AND/OR PROPERTY LOSS.
- FOR OUTDOOR HOUSEHOLD USE ONLY. NOT FOR COMMERCIAL USE.
- SOME PARTS MAY CONTAIN SHARP EDGES - ESPECIALLY WHERE NOTED IN THIS MANUAL! WEAR PROTECTIVE GLOVES IF NECESSARY.
- THESE INSTRUCTIONS MUST BE KEPT WITH THE CONSUMER AND RETAINED FOR FUTURE USE.

## IMPORTANT SAFEGUARDS



**WARNING:** Failure to follow these instructions could result in death, serious injury and/or property loss. Read and follow instructions carefully before using grill.

### General Safeguards

Following is a list of Important Safeguards to guide you through the grilling process for a successful and safe barbecue. It is important to remember; anytime you work with fire, there is a chance of getting burned. So take precautions! Common sense and planning will prevent injuries.

1. Always read the owners manual before using your grill and follow specific usage, assembly, and safety procedures. Contact the grill manufacturer if you have specific questions about the operation of your grill.
2. Barbecue grills are designed for outdoor use only. Never barbecue in your trailer, tent, house, garage, or any enclosed area because carbon monoxide may accumulate and kill you.
3. Set up grill in an open area away from buildings, dry leaves, or brush. Be sure to avoid high traffic areas and always barbecue in a well-ventilated area. Be aware of the wind blown sparks.
4. Never use a barbecue grill unless all parts of the unit are firmly in place and the grill is stable.
5. Should electrically operated accessories (i.e. rotisseries, etc.) be used, be sure they are properly grounded in accordance with local codes. Electrical cords should be placed away from walkways.
6. Use long-handled barbecue utensils to avoid burns and splatters.
7. Wear clothing that does not have hanging shirt tail, frills or apron strings, and use flame retardant mitts when adjusting hot vents.
8. To put out flare-ups, adjust the vents to lower the temperature. If you must douse the flames with a light spritz of water, first remove the food from the grill.
9. Use baking soda to control a grease fire and have a fire extinguisher handy. A bucket of sand or a garden hose should be near if you do not have a commercial extinguisher.
10. Never leave a grill unattended once it is lit.
11. Do not allow anyone to conduct any activities around the grill when the grill is in use, or immediately following its use. The grill body is hot during use and will remain hot for a period of time following its use. Never operate your grill near combustible surfaces.

**12. Open the hood carefully when cooking; the hot air and steam can burn.**

**13. Never attempt to move a hot grill.**

**The purpose of these safety tips is to set forth general safety practices and precautions for the operation and maintenance of barbecue grills. These tips are not intended to be an exhaustive treatment of the subject, and should not be interpreted as precluding other procedures, which would enhance safe barbecue grill operations.**

### **Charcoal/Wood Chunk Safety Tips**

- 1. Before lighting charcoal briquettes or wood chunks, form a pyramid and then apply lighter fluid to the briquettes/chunks. Wait until the fluid has soaked in before lighting.**
- 2. Lighter fluid should be capped immediately and placed a safe distance from the grill**
- 3. Never add lighter fluid to existing hot or warm coals.**
- 4. Never use gasoline, kerosene, alcohol or other volatile fluids as a starter. They can explode.**
- 5. As an alternative to lighter fluid, use an electric, solid, metal chimney, or other starter specifically made for lighting charcoal briquettes or wood chunks.**
- 6. After unplugging, remove a hot electric starter cautiously and be careful where you put it. Always allow starter to cool completely before storing.**
- 7. Never use an electric starter in the rain and/or when standing on wet ground.**
- 8. When using instant light briquettes, do not use lighter fluid, an electric starter, solid, or metal chimney starters. Do not add more instant light briquettes once the fire has been lit, add regular charcoal briquettes if more are needed.**
- 9. Once the barbecue grill has been lit, do not touch the charcoal briquettes/wood chunks to see if they are hot. Do not close Hood until ready to cook.**
- 10. Allow coals to burn out completely and let the ashes cool for 48 hours before disposing of them.**
- 11. Dispose of cold ashes by wrapping them in heavy-duty aluminum foil and putting them in a non-combustible container. Be sure there are no other combustible materials in or near the container.**
- 12. If you must dispose of the ashes in less time than it takes for them to completely cool, remove the ashes from the grill keeping them in heavy duty foil and soak them completely with water before disposing in a non-combustible container.**

## Food Safety Tips for Barbecuing

Barbecuing is popular year around, but people head to their backyards to fire up the grill in record numbers when the temperatures soar. Scrupulously following food safety guidelines is important at all times, but it becomes especially crucial during warm weather because escalating temperatures encourage bacteria and other pathogens to multiply and cause foodborne illness. Here are some simple guidelines to help ensure safe grilling.

2. When shopping for meat, fish, and poultry, put them in your grocery cart last. Never buy a package that's damaged or torn and check "sell-by" and "use-by" dates. Put packaged raw meat in plastic bags so leaking juices cannot cross contaminate other foods.
3. Load grocery bags with meat and other refrigerated foods in the air-conditioned section of the car, not in the trunk.
4. Take groceries home immediately or bring along a cooler with ice packs and place the meat in it. Refrigerate or freeze it as soon as possible.
5. When carrying food to a picnic, the beach, or a tailgating party, keep it cold. Use an insulated cooler with sufficient ice or ice packs to keep the food at 40° F. Remove food from the refrigerator and pack the cooler just before leaving the house.
6. If including take-out foods - such as deli potato salad, coleslaw or baked beans - eat within two hours of picking them up. Otherwise, purchase them in advance and chill thoroughly, then transport in a cooler and reheat those that should be hot just before eating.
7. If you won't use meat, fish, and poultry within a few days, freeze it immediately.
8. Store refrigerated meat in the coldest part of the refrigerator in its original packaging. The more times the food is handled the more chance of contamination. Put a plate under the package, or place in a plastic bag, to avoid juices dripping onto refrigerator shelves.
9. Thaw frozen food in the refrigerator, never on the counter; allow sufficient defrosting time. Or immerse packaged food in cold water to thaw. If you're in a hurry, thaw in the microwave just before grilling it.
10. Hand washing is paramount. Wash your hands in hot soapy water before preparing food, after each time you touch raw meat, and after any interruptions such as using the bathroom, handling pets, stopping to do something with children.
11. Keep raw meat, poultry, and fish and their juices away from other food. That means thoroughly washing cutting boards, knives, platters, etc. before letting them come in contact with other foods you're preparing or with cooked foods you're about to serve.
12. Sanitize cutting boards and countertops with chlorine bleach. Pour on small amount and let stand several minutes, rinse thoroughly and air dry or dry with clean paper towel. Soak sponges and dishcloths in hot soapy water to which you've added chlorine bleach.
13. Marinate foods in the refrigerator, never on the counter.

14. Boil any marinade to destroy bacteria. If you plan to baste with it or serve it with the cooked meat. Never save marinades for a second use.
  15. Pre-cook (chicken/ribs) immediately before grilling. Never let partially cooked food sit for more than a few minutes before tossing it on the grill to finish it.
  16. Cook meat thoroughly. Rare is no longer de rigueur! Use a meat or "instant read" thermometer to ensure a safe internal temperature. As a guideline, poultry 180° F (breasts 170° F), beef, lamb, veal roast/steaks 145° F to 160° F, any burgers 160° F, all pork 160° F.
- 

## **CARING FOR YOUR GRILL**

**Wood Cart-**Your wood Cart is manufactured with a hardwood suited for outdoor use. To maintain its condition and appearance, annual application of polyurethane is recommended. (Never apply polyurethane to a hot grill. It is flammable!)

- Follow all instruction and warnings listed on the polyurethane container.
- Always use a brush to apply the polyurethane; do not use a spray can.
- Do not apply polyurethane to the metal grill body.

**Porcelain Hood-** Clean the porcelain hood with mild soap and water and rinse. Do not use steel wool or abrasive cleansers or other products on the porcelain coated surfaces. These will scratch the surfaces.

**Cooking Grids-** Steel wool and scouring products can be used to clean the grids.

**NOTE:** Keep your grill covered when possible. Periodically check and tighten all bolts, nuts and screws.

---

## **MODEL 7652 CHARCOAL GRILL ASSEMBLY INSTRUCTIONS**













**PREPARATION FOR ASSEMBLY:** Removing parts from carton and some assembly will require two people. Before starting assembly, read the instructions and your manual.

Beginning on next page, remove all the parts from the carton and lay them on a smooth, clean surface. (You may cut the carton; spread it out and use it for a pad to protect part finishes.) Look in the Parts List under your model number to find the exact parts you need. Do not throw away any of the packaging until you have located all the parts.













Follow instructions of each step in the order they are written as you view the diagrams. This will minimize confusion and allow easier assembly. If you have any questions which require help, contact Customer Service (1-800-251-7558) and be sure to mention the model number of your grill.

**TOOLS:**  **OR**  **AND**  **Adjustable Wrench**

### PARTS KIT

ITEM	PART/DESCRIPTION	PART #	QTY.	MODEL
1	Side Table 	03.5845.00	2	All Models
2	Wheel Leg 	03.6085.00	2	All Models
3	Bolt, 1/4" x 1" 	03.4062.00	24	All Models
4	Front Fixed Leg 	03.6066.00	2	All Models
5	Bottom Shelf 	03.6067.00	1	All Models
6	Axle 	03.5014.00	1	All Models
7	Steel Washer 	03.4072.00	2	All Models
8	Wheel 	03.5003.00	2	All Models
9	Axle Locknut 	03.4073.00	2	All Models
10	Grill Body 	03.6068.00	1	All Models
11	Drip Pan 	03.6069.00	1	All Models
12	Bolt, 6mm 	03.6070.00	8	All Models
13	Tubular Collar 	03.6071.00	8	All Models

### PARTS KIT

ITEM	PART/DESCRIPTION	PART #	QTY.	MODEL
14	Slide Vant 	03.6072.00	2	All Models
15	Nut, 6mm 	03.6073.00	8	All Models
16	Bolt, 6mm x 90mm 	03.6020.00	2	All Models
17	Hood Handle 	03.6036.00	1	All Models
18	Handle Spacer 	03.6023.00	2	All Models
19	Locknut, 6mm 	03.4070.00	2	Model 7652
20	Spacer 	03.4074.00	8	All Models
21	Bolt, 6mm x 110mm 	03.4086.00	8	All Models
22	Wingnut 	03.6003.00	8	All Models
23	Charcoal Holder 	03.6074.00	1	All Models
24	Cooking Grid 	03.6075.00	2	All Models
25	Grid Holder 	03.6076.00	2	All Models
26	Owners Manual 	03.6077.00	1	All Models

## STEP 1-LEG/SIDE TABLE ASSEMBLY

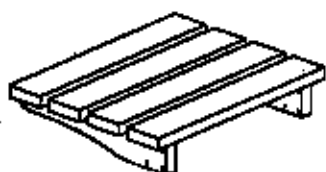

(ITEM 1)  
SIDE TABLE  
2 pcs

(ITEM 2)  
WHEEL LEG  
2 pcs

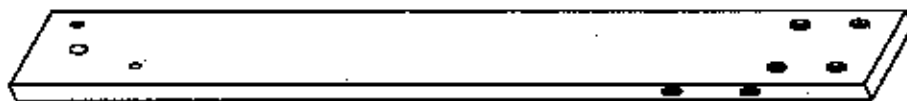

(ITEM 4)  
FIXED LEG  
2 pcs

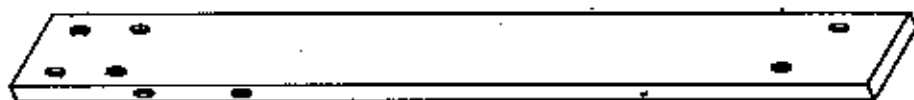

(ITEM 3 ACTUAL SIZE)  
1/4" x 1" BOLT  
16 pcs

- Lay Side Tables (1) upside down on flat surface as shown.
- Align four recessed holes of each Wheel Leg (2) (the two shorter legs with a large axle hole at one end) with those of the side table. The four large recessed holes of the Wheel Leg should face away from Side Table (1).
- Insert four 1/4" x 1" Bolts (3) through each Wheel Leg into the threaded holes of the first Side Table. Do not tighten bolts completely.
- Attach the two Fixed Legs (4) to the second Side Table the same way. Do not tighten bolts completely.

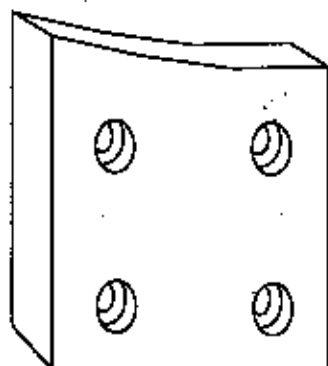

FOUR LARGE  
RECESSED HOLES  
IN LEGS

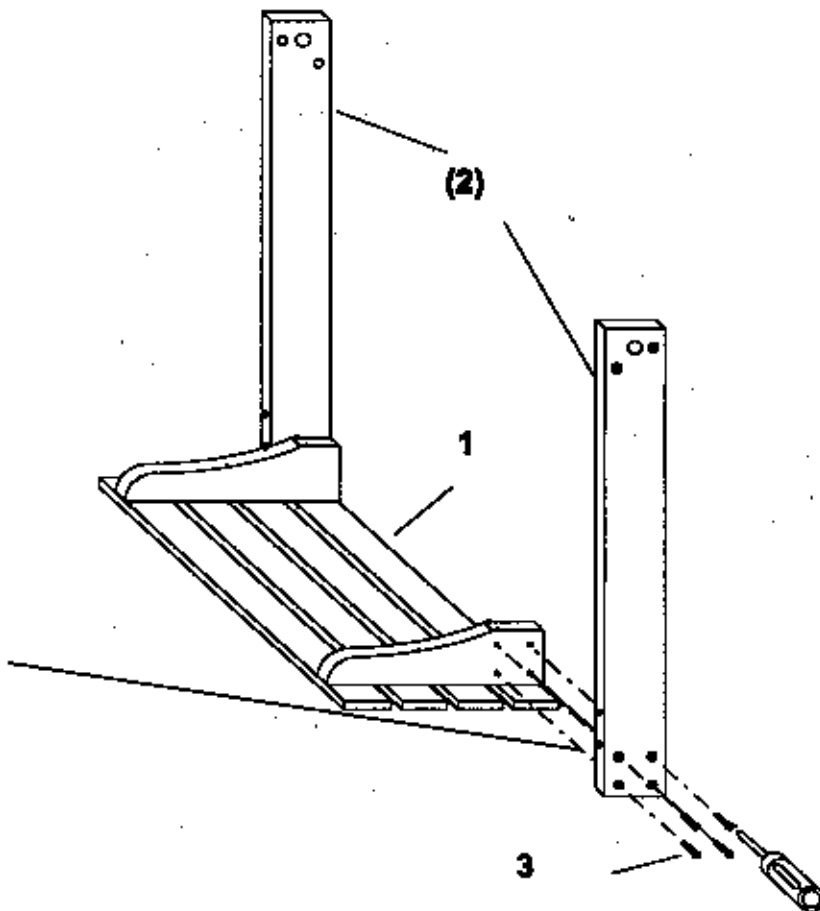

## STEP 2-BOTTOM SHELF/LEG ASSEMBLY



(ITEM 3 ACTUAL SIZE)  
1/4" x 1" BOLT  
8 pcs



(ITEM 5) BOTTOM SHELF

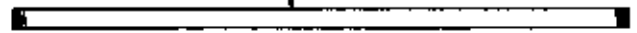

(ITEM 6) AXLE

WHEEL LEG/SIDE TABLE ASSEMBLY FROM STEP 1

FIXED LEG/SIDE TABLE ASSEMBLY FROM STEP 2

- Place both Leg/Side Table Assemblies opposite each other as shown with Bottom Shelf (5) between them. Align axle holes of Bottom Shelf with axle holes in Wheel Legs and insert Axle (6) through both sides of Wheel Legs and Bottom Shelf.
- Align opposite end of Bottom Shelf with holes of Fixed Legs (4) and attach using 1/4" x 1" Bolts (3). Do not tighten Bolts completely. (To aid easier alignment, final tightening of all bolts will be completed in Step 6).
- Secure Wheel Legs (2) to Bottom Shelf (5) using 1/4" x 1" Bolts (3). Tighten Wheel Leg bolts securely and leave Axle in place.

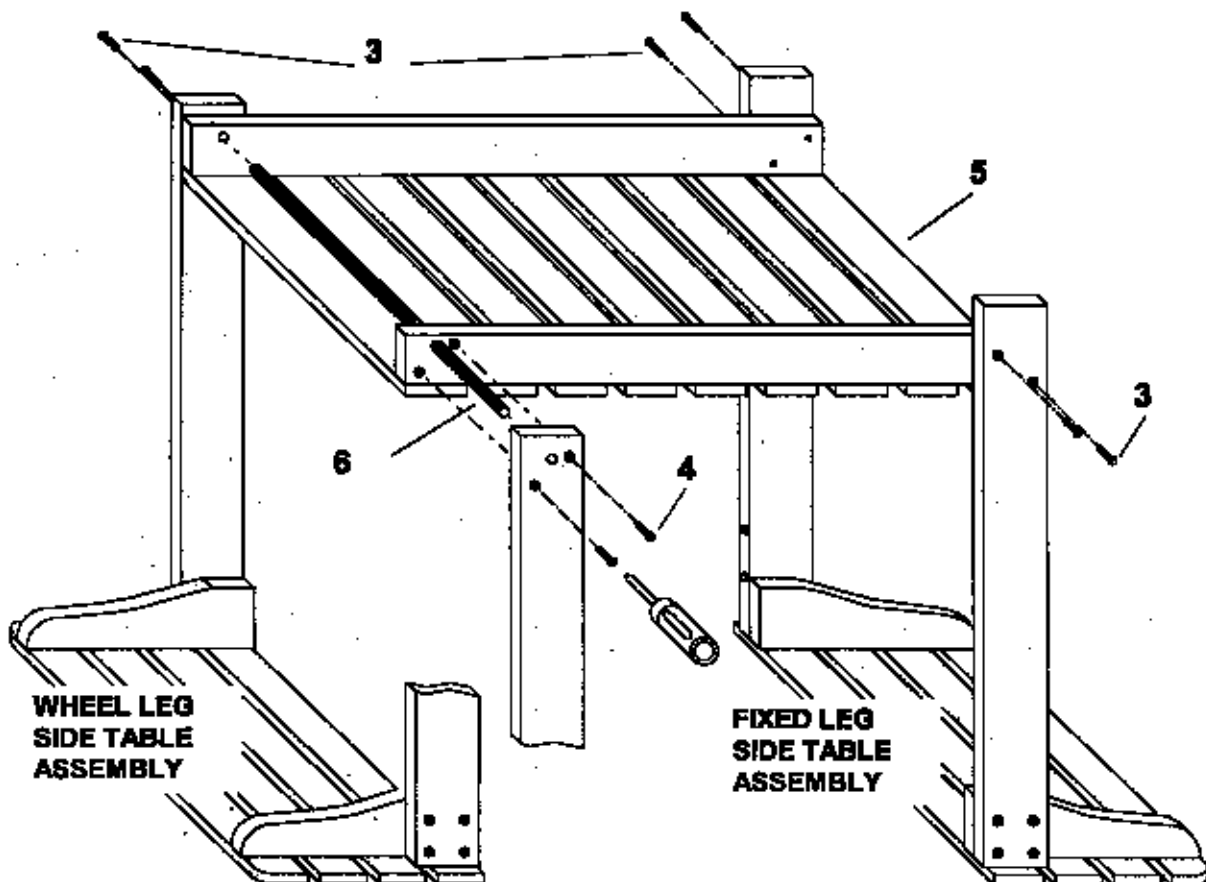

### **STEP 3-WHEEL ASSEMBLY**



**(ITEM 7) STEEL WASHER**  
2 pcs

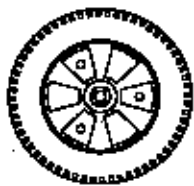

**(ITEM 8) WHEEL**  
2 pcs



**(ITEM 9) AXLE NUT**  
2 pcs

•Place Steel Washers (7) onto each end of Axle (6). Position recessed center hole of Wheels (8) to the outside and slide a Wheel onto each end of Axle (6).

•Attach Axle Locknut (9) onto each end of Axle (6). Tighten with adjustable or 9/16" open-end wrench.

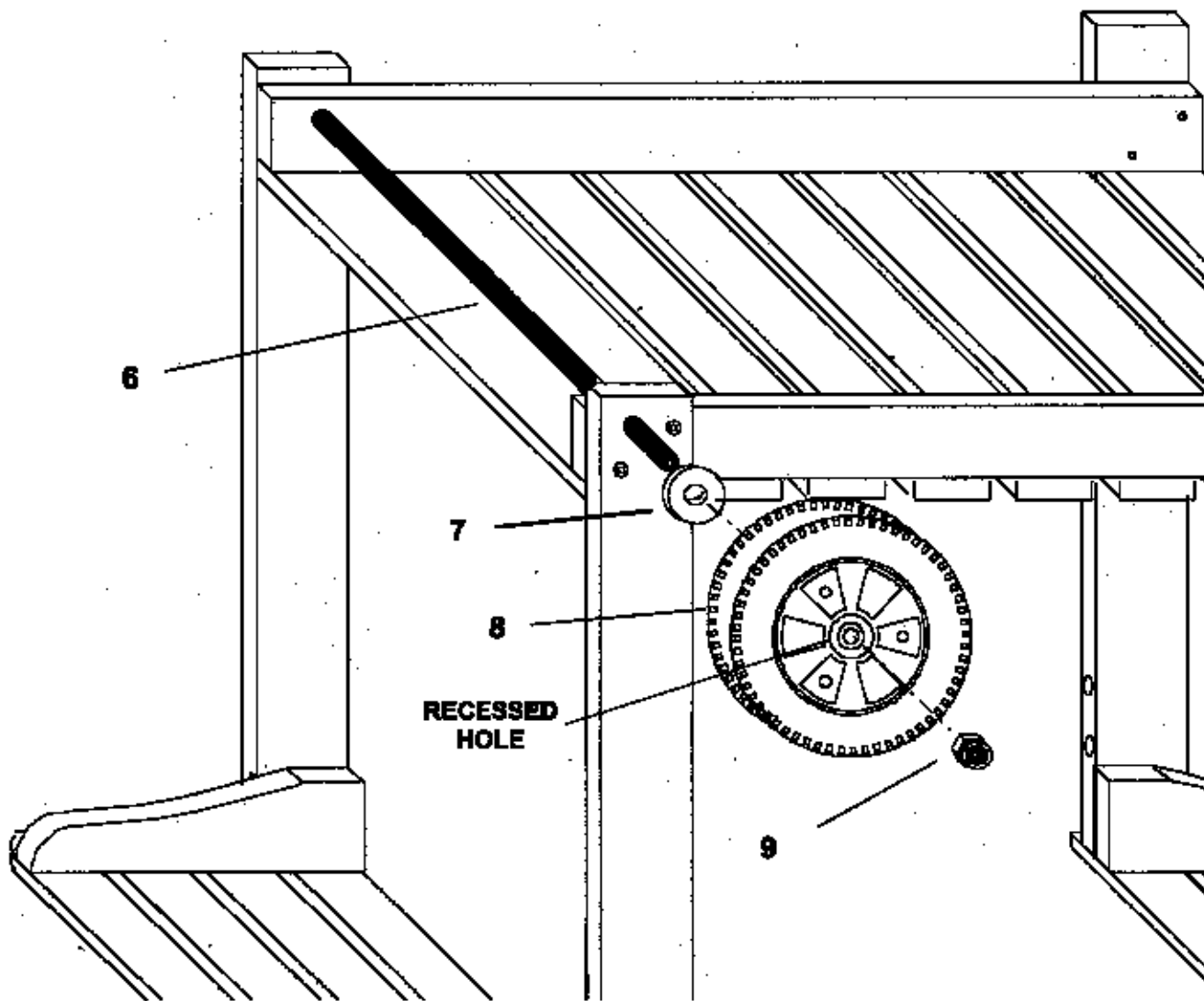

## STEP 4-SLIDE VENT ASSEMBLY

(ITEM 10)  
Grill Body

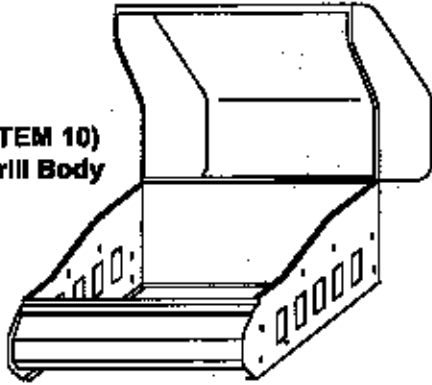

(ITEM 11)  
Drip Pan



(ITEM 12)  
6mm Bolt  
8 pcs

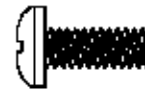

(ITEM 13)  
Tubular Collar  
8 pcs



(ITEM 14)  
SLIDE VENT  
2 pcs

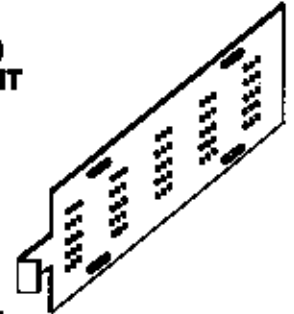

(ITEM 15)  
Hex Nut 6mm  
8 pcs



**Note:** Assembly of Grill Body will require two people.

**CAUTION:** Some parts inside of Grill Body may have sharp edges or corners.

•Remove Drip Pan (11) from under the Grill Body (10).

•Align slotted holes in Slide Vent with holes in Grill Body Side.

•Insert a 6 mm Bolt (12) through a Tubular Collar (13) and position the Tubular Collar inside Slide Vent slotted hole. Attach 6 mm Hex Nut (15) to Bolt from inside of Grill Body to secure the Slide Vent. Repeat for each slotted hole on both Slide Vents. Make sure the Vents slide back and forth freely over the Tubular Collars.

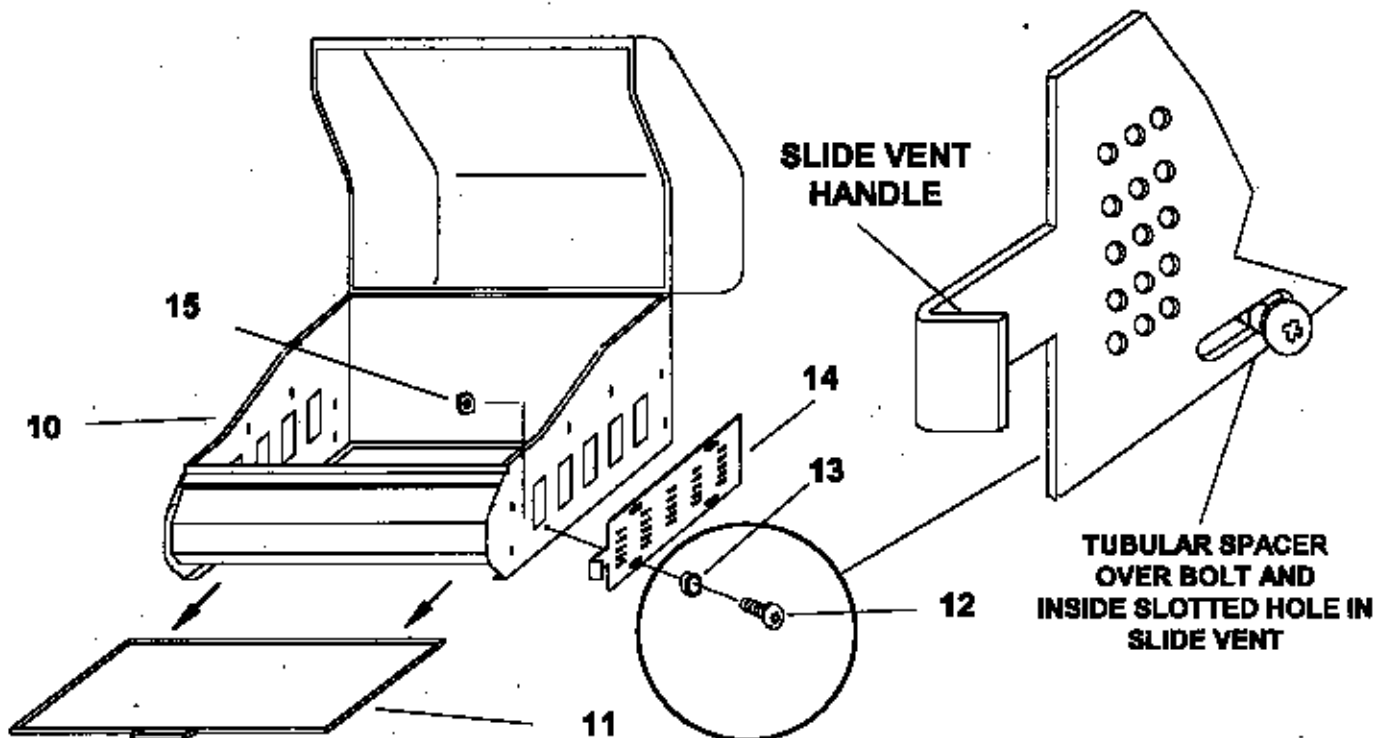

## STEP 5-HOOD HANDLE ASSEMBLY



(ITEM 16 ACTUAL SIZE)  
6mm x 90mm BOLT  
2 pcs

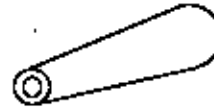

(ITEM 18)  
HANDLE SPACER  
2 pcs



(ITEM 19)  
6mm LOCKNUT  
2 pcs

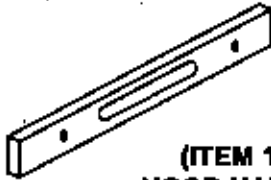

(ITEM 17)  
HOOD HANDLE

•Insert 6mm x 90 mm Bolt (16) through recessed hole of Hood Handle (17), through Handle Spacer (18) through a hole in Hood. Attach 6 mm Locknut (19) to the Bolt from Hood. **Do not overtighten; it may crack the hood finish.** Repeat for other side.

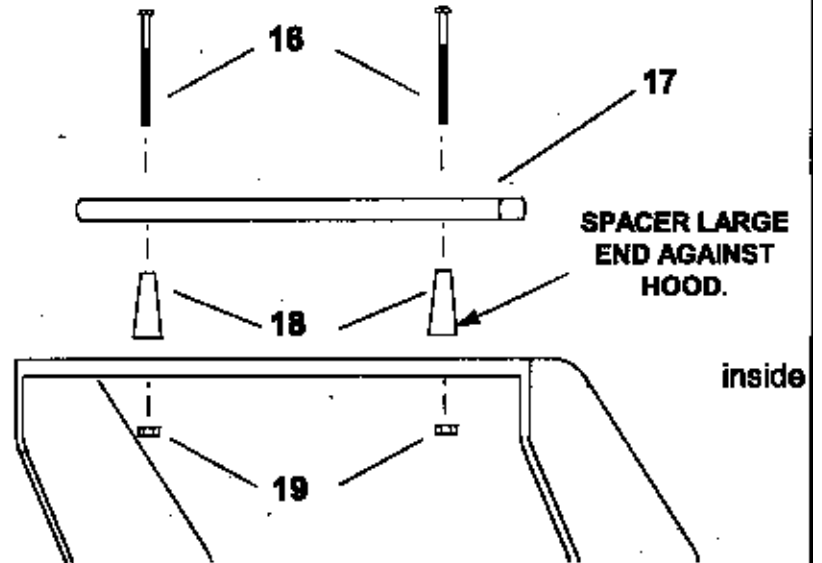

## STEP 6-GRILL BODY/CART ASSEMBLY

GRILL BODY ASSEMBLY

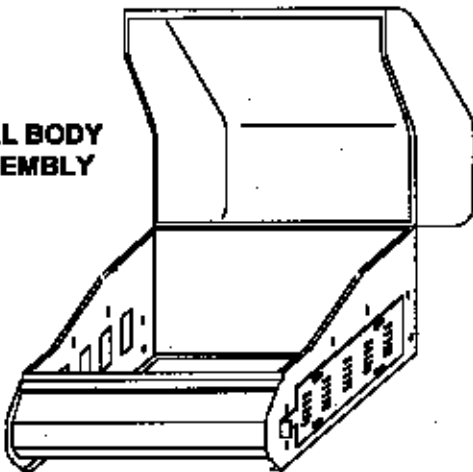

(ITEM 20) SPACER  
8 pcs



(ITEM 22) 6mm WING NUT  
8 pcs



(ITEM 21 ACTUAL SIZE)  
6mm X 110mm BOLT  
8 pcs

**Note: Assembly of Grill Body will require two people.**

**STEP 6 CONTINUED NEXT PAGE.**

## STEP 6-(CONTINUED) GRILL BODY/CART ASSEMBLY

•Handle the Grill Body carefully to protect the Body finish. Lay Grill Body Assembly on its back side with Front panel facing up and Hood open. Lay Cart Assembly on its side with the Grill Body between Side Tables.

•Align slotted holes on sides of Grill Body Assembly with holes in edges of legs (FIG. A). Hold Spacers (20) between Leg and Grill Body. (Hold Spacers with pliers if needed.) Insert two 6mm x 110mm Body Bolts (21) through Leg, Spacers and slotted holes in Grill Body. Attach a 6mm Wing Nut (22) to the Bolts, but do not tighten. Repeat this assembly for remaining three Cart Legs.

•With help from a second person, turn full Grill and Cart Assembly upright. The Grill Body should slide down to seat itself within the slotted holes. If not, loosen the Body bolts and push down at all four corners.

•Tighten all Body Bolts and Wing Nuts.

•Tighten all other Bolts at his time.

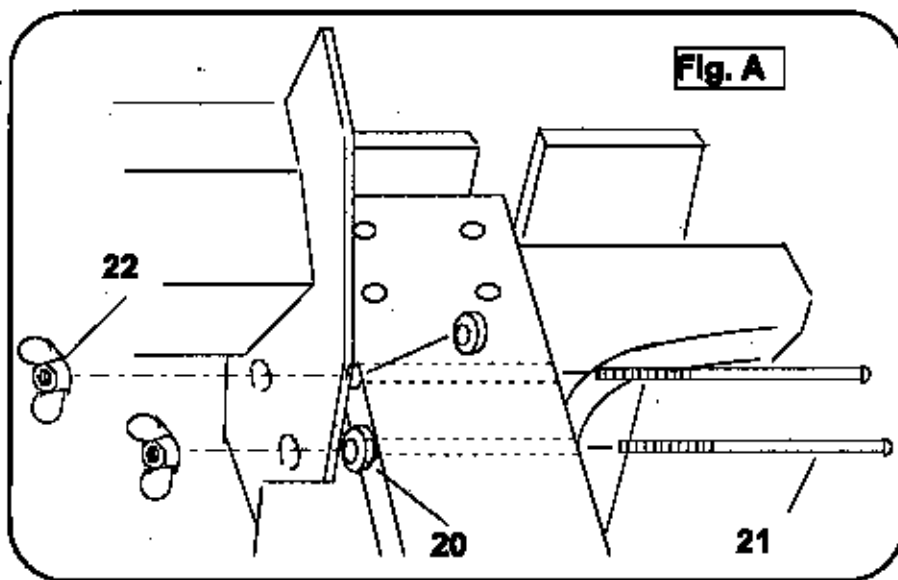

FRONT PANEL UP  
GRILL BODY LYING  
ON BACK SIDE

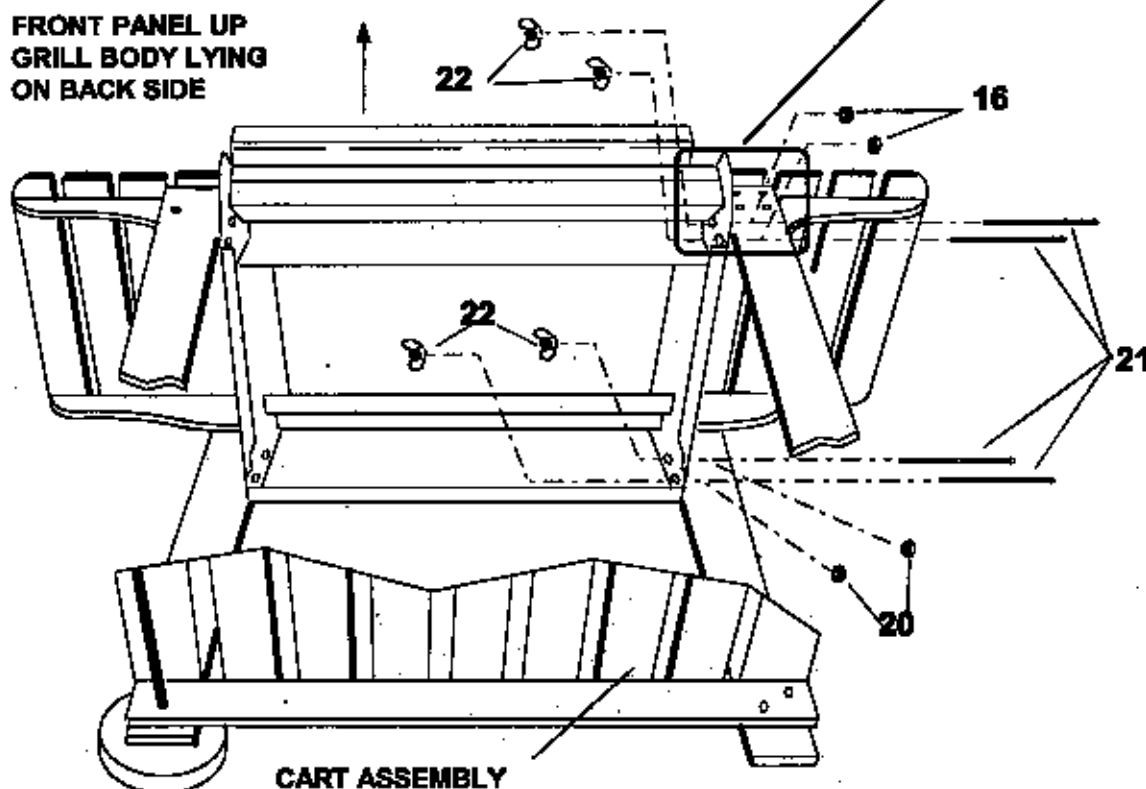

## **STEP 7-INSTALL DRIP PAN, CHARCOAL HOLDER & GRID**

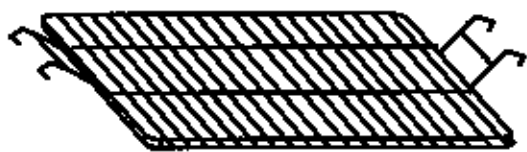

**(ITEM 23)  
CHARCOAL HOLDER**

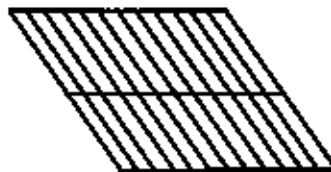

**(ITEM 24)  
COOKING GRID  
2 PCS**

- Slide Drip Pan back into Grill Body. Make sure the Drip Pan is pushed all the way in.
- Hang Charcoal Holder (23) inside Grill Body by hooking the handles inside the 2 slots on each side of the Grill Body.
- Lay the Cooking Grids (24) on the front and rear body shoulders over the Charcoal Holder.

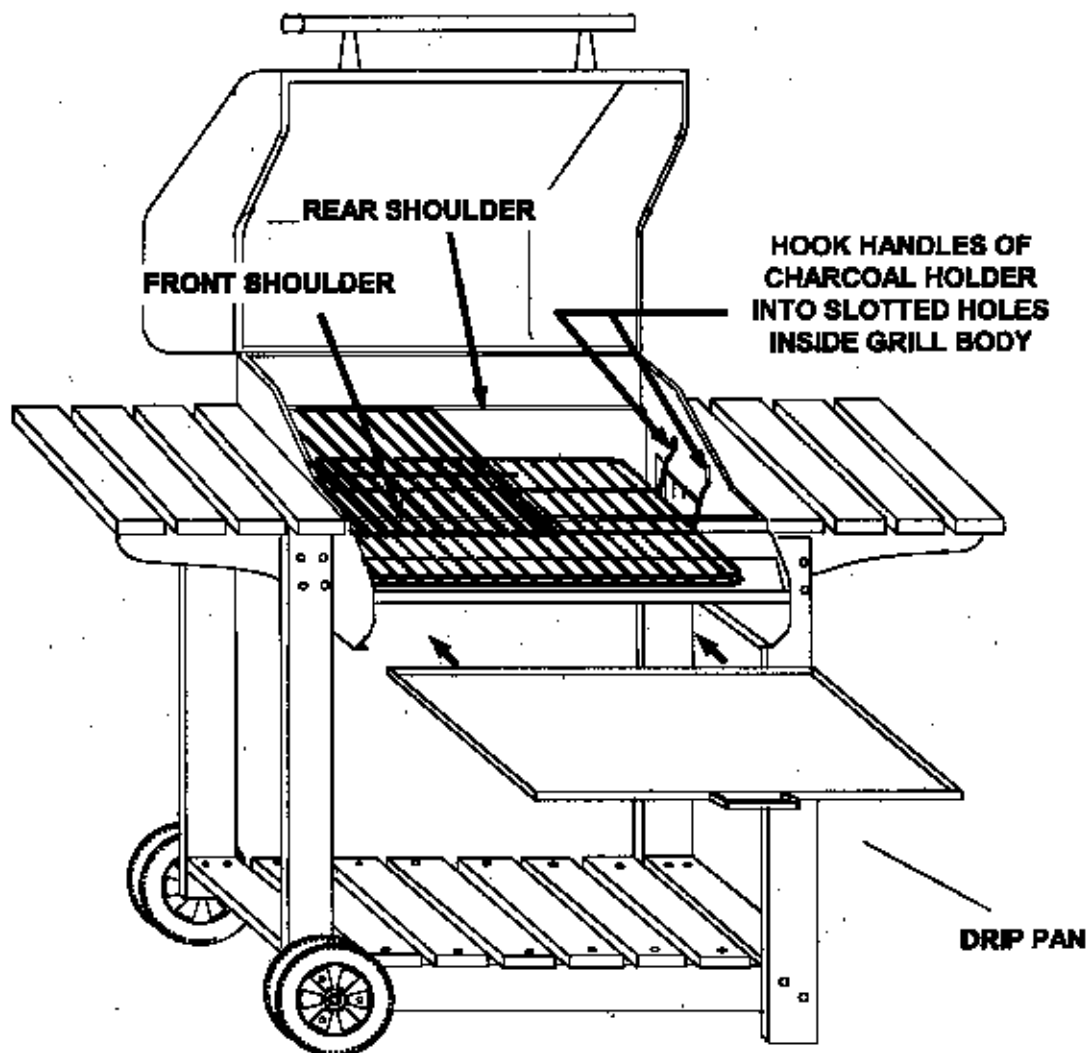

## **USE OF GRID HANDLE**



(ITEM 25)  
GRID HANDLE  
2 pcs

• Do not move hot Cooking Grids. Let grids cool completely before handling. Hook the notched end of the Grid Handle between the wires on the front edge of the Cooking Grid, then lift the grid carefully.

## **STARTING YOUR AUSSIE CHARCOAL GRILL**



Only use your grill in a place with good ventilation. Do not use charcoal for indoor cooking or heating. Toxic carbon monoxide gases may accumulate and cause death.

Never use gasoline, kerosene, or alcohol to start a charcoal fire.

### **WARNING**

Never use the grill without the Drip Pan properly installed.

Do not close the hood until the flames have died down.

## **STARTING A FIRE**

**STEP 1.** Select a high quality hardwood charcoal. Charcoal briquettes made from maple, oak, birch or elm woods are recommended.

**STEP 2.** Open the hood and all the vents.

**STEP 3.** Remove the Cooking Grids (if installed). Make sure the Drip Pan is pushed all the way in.

**STEP 4.** Place about five pounds of charcoal (72-75 briquettes) within the Charcoal Holder.

**STEP 5.** Make a pyramid shaped stack near the front of the Charcoal Holder.

**STEP 6a.** For regular charcoal or wood, apply the charcoal lighter fluid, following the container instructions. Allow the lighter fluid to soak in for approximately one minute.

**STEP 6b.** For instant light briquettes, do not use lighter fluid, electric, solid, or metal chimney starters.

**STEP 7.** Carefully light charcoal with a match, lighter or starter. Allow Charcoal to burn for about 30 minutes or until it is covered with a light gray ash.

**Step 8.** Using long-handled tongs and barbecue mitts, spread the charcoal inside the Charcoal Holder, leaving about one-half inch of space between each piece of charcoal. This will help to avoid flare-up from the meat drippings and provide more even heat for grilling

**STEP 9.** Replace the Cooking Grids. You are ready to begin grilling.

**FAVORITE RECIPES/NOTES:**

# AUSSIE™

P/N 03.8077.00  
REL. 10/00